

Programming Design

Functions

Ling-Chieh Kung

Department of Information Management
National Taiwan University

Functions

- In C++ and most modern programming languages, we may put statements into **functions** to be **invoked** in the future.
 - Also known as **procedures** in some languages.
- Why functions?
- We need **modules** instead of a huge main function.
 - Easier to divide the works: **modularization**.
 - Easier to debug: **maintenance**.
 - Easier to maintain **consistency**.
- We need something that can be used repeatedly.
 - Enhance **reusability**.

Outline

- **Basics of functions**
- More about return values
- Scope of variables revisited
- Advances of functions

Structure of functions

- In C++, a function is composed of a **header** and a **body**.
- A header for **declaration**:
 - A function name (identifier).
 - A list of input parameters.
 - A return value.
- A body for **definition**:
 - Statements that define the task.

Input parameters

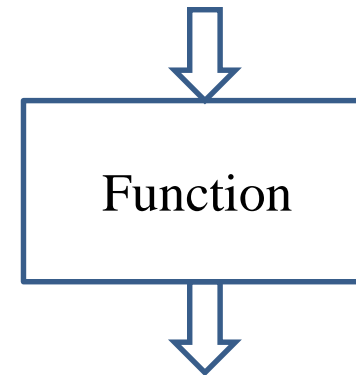

A returned value

Structure of functions

- There are two types of functions:
 - **System-defined functions.**
 - **User-defined functions.**
- System-defined functions are defined in the C++ standard library.
 - To include the definition, use **#include**.
 - **<iostream>**, **<iomanip>**, **<cmath>**, **<climits>**, etc.
 - Those from C are named by adding “c” as the initial.
- To study user-defined functions, let’s start from an example.

```
#include <iostream>
#include <cmath>
using namespace std;

int main ()
{
    int c = 0;
    cin >> c;
    cout << abs(c) << "\n";
    return 0;
}
```

Function definition

- There is an **add()** function:
- In the main function we invoke (call) the **add()** function.
- Before the main function, there is a function **header/prototype** declaring the function.
- After the main function, there is a function **body** defining the function.

```
#include <iostream>
using namespace std;

int add(int, int);
int main()
{
    int c = add(10, 20);
    cout << c << "\n";
    return 0;
}
int add(int num1, int num2)
{
    return num1 + num2;
}
```

Function declaration

- To implement a function, we first declare its **prototype**:

```
return type function name(parameter types);
```

- In a function prototype, we declare its **appearance** and input/output **format**.

```
int add(int, int);
```

- The name of the function follows the same rule for naming variable.
- A list of (zero, one, or multiple) **parameters**:
 - The parameters passed into the function with their types.
 - We must declare their **types**. Declaring their names are optional.
- A **return type** indicates the type of the function return value.

Function declaration

- Some examples of function prototype:

- A function receives two integers and returns an integer.
- The parameter names may provide “hints” to what this function does.
- A function receives two **double** and returns one **double**.

```
int add(int num1, int num2);  
int add(int, int);
```

```
double divide(double, double);  
double divide(double num, double den);
```

- For a function declaration, the **semicolon** is required.
- Every type can be the return type.
 - It may be “**void**” if the function returns nothing.

Creating a function

- Declare the function before using it.
 - Typically after the preprocessors and **before** the main function.
- Then we need to **define** the function by writing the function **body**.
 - Typically **after** the main function, though not required.
- In a function definition, we need to specify parameter **names**.
- These parameters can be viewed as **variables** declared **inside** the function.
 - They can be accessed only in the function.

```
int add(int num1, int num2)
{
    return num1 + num2;
}
```

Function definition

- You have written one function: the **main** function.
- Defining other functions can be done in the same way.

```
return type function name(parameters)  
{  
    statements  
}
```

- The first line, the function header, is almost identical to the prototype.
- The parameter **names** must be specified.
- Statements are then written for a specific task.
- The keyword **return** terminates the function execution and returns a value.

```
int add(int num1, int num2)  
{  
    return num1 + num2;  
}
```

Function invocation

- When a function is invoked in the main function, the program execution **jumps** to the function.
- After the function execution is complete, the program execution jumps **back** to the main function, exactly where the function is called.
- What if another function is called in a function?

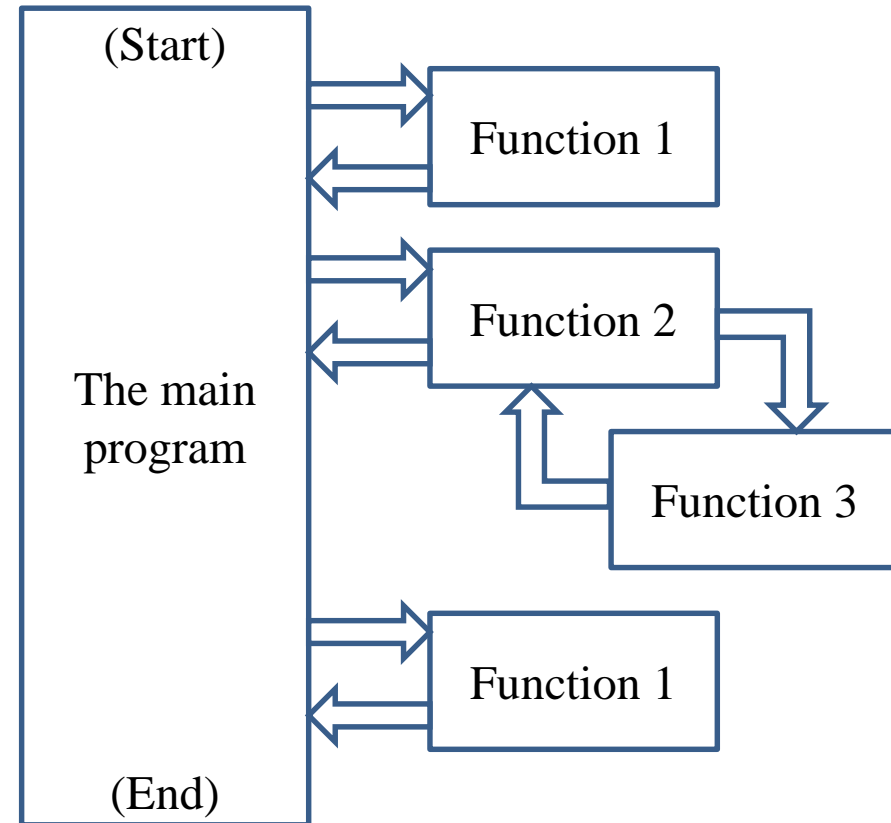

Function invocation

```
int add(int, int);
void test(int);
int main()
{
    int c = add(10, 20);
    cout << c << "\n";
    return 0;
}
int add(int num1, int num2)
{
    test(num1);
    return num1 + num2;
}
void test (int toPrint)
{
    cout << toPrint << "\n";
}
```

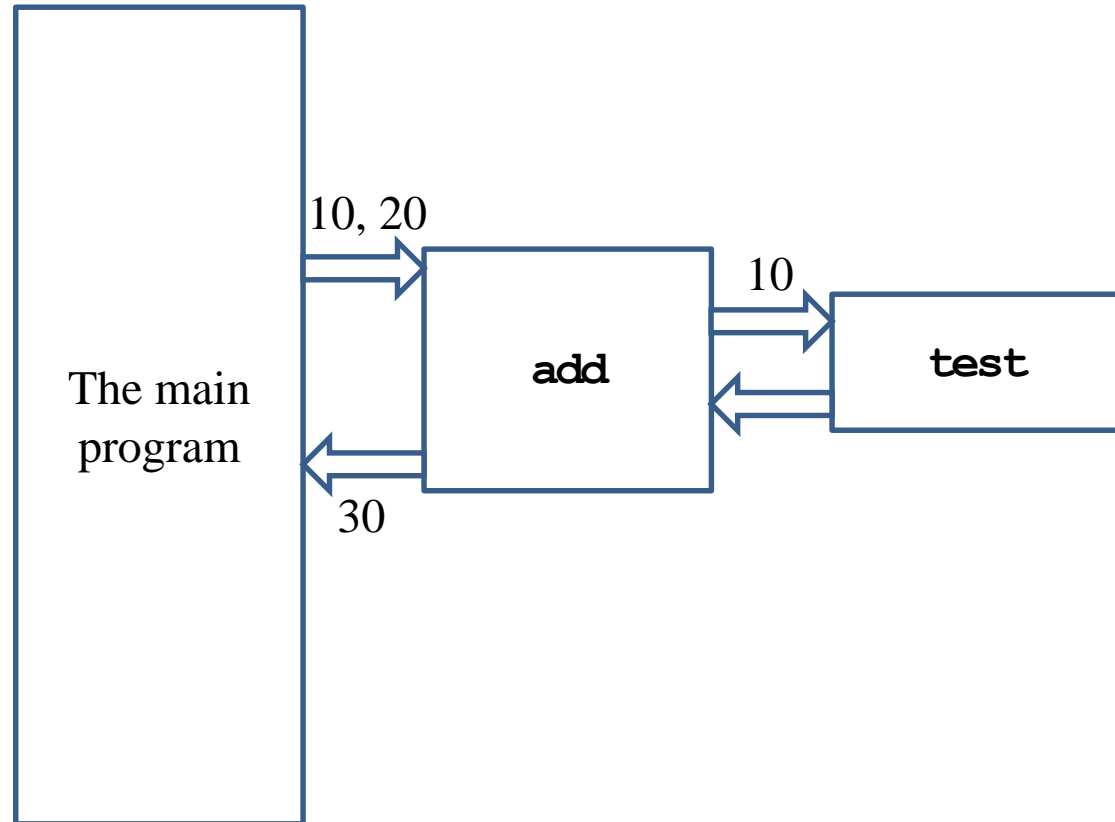

Function declaration and definition

- You may choose to define a function before the main function.
 - In this case, the function prototype can be omitted.
- In any case, you must **declare** a function **before** you use it.

```
int add(int num1, int num2)
{
    return num1 + num2;
}

int main()
{
    // fine!
    int c = add(10, 20);
    cout << c << "\n";
    return 0;
}
```

```
void a()
{
    // error!
    b();
}

void b()
{
    ;
}

int main()
{
    a();
    b();
    return 0;
}
```

Function declaration and definition

- In some cases, function prototypes must be used.

```
void a ()
{
    // error!
    b();
}
void b()
{
    a();
}
```

```
int main ()
{
    a();
    b();
    return 0;
}
```

```
void a ();
void b ();
int main ()
{
    a();
    b();
    return 0;
}
```

```
void a ()
{
    // fine!
    b();
}
void b ()
{
    a();
}
```

- Direct or indirect self-involutions are called recursion (a topic to be discussed in the next lecture).
- Using function prototypes also enhances communications and maintenance.

Function parameters vs. arguments

- When we invoke a function, we need to provide **arguments**.
 - **Parameters** (also called formal parameters) are used inside the function.
 - **Arguments** (also called actual parameters) are passed into the function.
 - If a pair of parameter and argument are both variables, their names can be different.
- Let's visualize the memory events.

```
int add(int num1, int num2)
{
    return num1 + num2;
}
int main()
{
    double q1 = 10.5;
    double q2 = 20.7;
    double c = add(q1, q2 - 3);
    cout << c << "\n";
    return 0;
}
```

Function arguments

- Function arguments can be:
 - Literals.
 - Variables.
 - Constant variables.
 - Expressions.
- If an argument's type is different from the corresponding parameter's type, compiler will try to **cast** it.

```
int add(int, int);
int main()
{
    const int C = 5;
    double d = 1.6;
    cout << add(10, 20) << "\n";
    cout << add(C, d) << "\n";
    cout << add(10 * C, 20) << "\n";
    return 0;
}

int add(int num1, int num2)
{
    return num1 + num2;
}
```

Function return value

- We can return **one or no** value back to where we invoke the function.
- Use the **return** statement to return a value.
- If you do not want to return anything, declare the function return type as **void**.
 - In this case, the **return** statement can be omitted.
 - Or we may write **return;**.
 - Otherwise, having no **return** statement results in a compilation error.

Function return value

- There can be multiple **return** statements.
- A function runs until the **first return** statement is met.
 - Or the end of the function for a function returning **void**
- We need to ensure that at least one return will be executed!

```
int max(int a, int b)
{
    if(a > b)
        return a;
    else
        return b;
}
```

```
int test(int);

int main()
{
    cout << test(-1);
    return 0;
}

int test(int a)
{
    if(a > 0)
        return 5;
}
```

Coupling and decoupling

- What do these two functions do?

```
int factorial(int n)
{
    int ans = 1;
    for(int a = 1; a <= n; a++)
        ans *= a; // ans = ans * a;
    return ans;
}
```

```
void factorial(int n)
{
    int ans = 1;
    for(int a = 1; a <= n; a++)
        ans *= a; // ans = ans * a;
    cout << ans;
}
```

- Which one to choose?
- General rule: Minimize the degree of **coupling** in your program.
 - **Decouple** your program with appropriate functions.

Good programming style

- **Name a function** so that its purpose is clear.
- In a function, **name a parameter** so that its purpose is clear.
- Declare all functions with **comments**.
 - Ideally, other programmers can understand what a function does without reading the definition.
- Declare all functions **at the beginning** of the program.
- **Decouple** your program with appropriate functions.

Outline

- Basics of functions
- **More about return values**
- Scope of variables revisited
- Advances of functions

return statements in a void function

- In a **void** function, there is no need for a return statement.
 - One may still add some if they help.
- Consider the following example:
 - Given an input integer, write a program that prints out its digits, from the least significant to the most significant.
 - Print out nothing if the input number is negative.

Implementation with no return

- This function works:

```
void reversePrint(int i)
{
    if(i >= 0)
    {
        while(i > 0)
        {
            cout << i % 10;
            i /= 10;
        }
    }
}
```

```
#include<iostream>
using namespace std;

void reversePrint(int);
int main()
{
    int i = 0;
    cin >> i;
    reversePrint(i);
    return 0;
}
```

Implementation with return

- This function also works:

```
void reversePrint(int i)
{
    if(i < 0)
        return;
    while(i > 0)
    {
        cout << i % 10;
        i /= 10;
    }
    return;
}
```

```
#include<iostream>
using namespace std;

void reversePrint(int);
int main()
{
    int i = 0;
    cin >> i;
    reversePrint(i);
    return 0;
}
```

- Adding **return** may **improve readability** and/or **highlight some parts**.

Operators also return value

- An **operator** can also be viewed as a function.
 - They take operand(s) as input(s), process them, and return a value.
 - E.g., **+** returns the sum of the two operands.
 - The return value of an operator can be very useful.
- **cin >>** and **cout <<** also have return values.
 - Let's consider **cin >>** as an example. What is the return type?
 - <http://www.cplusplus.com/reference/istream/istream/operator%3E%3E/>
 - **istream&** is an **input stream**; **&** will be explained in the future.
- Though **istream&** is hard to understand, it is not too hard to use it.
 - Let's see how to use the return value of **cin >>** to make better programs.

Utilizing the return value of `cin` >>

- Consider this simple program:
 - The user may keep entering values until she enters a negative number.
 - The sum of all numbers except the negative one will be printed.
 - The number of input values is unlimited.
- We may let our program read input **from a file**.
 - In MS Windows, use the “<” operator in “cmd”.
- May we remove the setting of using a negative number as the ending signal?

```
int main()
{
    int sum = 0;
    int i = 0;

    cin >> i;
    while(i >= 0)
    {
        sum += i;
        cin >> i;
    }
    cout << sum;

    return 0;
}
```

Utilizing the return value of `cin >>`

- The modified program is:
- The input stream returned by `cin >>` can be evaluated.
 - If **nothing is read** in this operation, evaluating the input stream will result in a **false** value.
 - The loop can then be terminated.
- This works when we read input from a file.
 - If the user enters numbers through a keyboard, the input stream will not end. This will of course fail.

```
int main()
{
    int sum = 0;
    int i = 0;

    while(cin >> i)
    {
        sum += i;
    }
    cout << sum;

    return 0;
}
```

Utilizing the return value of `cin >>`

- The program may be modified in this way (only for illustration purpose):
 - `is` is an `istream&` object.
 - It can be cast to a Boolean variable.
 - If there is nothing in the input stream, the Boolean value will be false.

```
int main()
{
    int sum = 0;
    int i = 0;

    istream& is = (cin >> i);
    bool b = static_cast<bool>(is);
    while (b)
    {
        sum += i;
        b = (cin >> i);
    }
    cout << sum;

    return 0;
}
```

Utilizing the return value of `cin` >>

- Suppose the following problem exists in your homework:
 - In the input file, there are $n + 1$ integers, separated by white spaces.
 - The first integer is n .
 - Your program should print out the sum of the last n integers.
- A correct program is here:

```
int main()
{
    int n = 0;
    int sum = 0;
    cin >> n;
    for(int i = 0; i < n; i++)
    {
        int i = 0;
        cin >> i;
        sum += i;
    }
    cout << sum;

    return 0;
}
```

Utilizing the return value of `cin` >>

- Suppose the following problem exists in your homework:
 - In the input file, there are n integers, separated by white spaces.
 - Your program should print out the sum of the n integers.
- A correct program is here (exactly the one presented three slides ago):

```
int main()
{
    int sum = 0;
    int i = 0;

    while(cin >> i)
    {
        sum += i;
    }
    cout << sum;

    return 0;
}
```

Outline

- Basics of functions
- More about return values
- **Scope of variables revisited**
- Advances of functions

Variable lifetime

- Four levels of variable lifetime (life scope) in C++ can be discussed now.
 - Local, global, external, and static variables.
- We'll discuss more types of variables in this semester.

Local variables

- A **local** variable is declared in a **block**.
 - It lives from the declaration to the end of block.
- In the block, it will **hide** other variables with same name.

```
int main()
{
    int i = 50; // it will be hidden
    for(int i = 0; i < 20; i++)
    {
        cout << i << " "; // print 0 1 2 ... 19
    }
    cout << i << "\n"; // 50
    return 0;
}
```

Global variables

- A **global** variable is declared **outside** any block (thus outside the main function)
 - From declaration to the end of the program.
 - It will be **hidden** by any local variable with the same name.
 - To access a global variable, use the scope resolution operator `::`.
- There's no difference in the way you declare a local or global variable. The **locations** matter.
- We may add **auto** to declare a local or global variable, but since it is the default setting, almost no one adds this.

```
#include <iostream>
using namespace std;

int i = 5;

int main()
{
    for(; i < 20; i++)
        cout << i << " "; // ?
    cout << "\n";
    int i = 2;
    cout << i << "\n"; // ?
    cout << ::i << "\n"; // ?
    return 0;
}
```

External variables

- In a large-scale system, many programs run together.
- If a program wants to access a variable **defined in another program**, it can declare the variable with the keyword **extern**.
 - **extern int a;**
 - **a** must have been defined in another program.
 - These programs must run together.
- You will not need this now... actually you should try to **avoid** it.
 - It hurts modularization and makes the system hard to maintain.
 - Though it still exists in some old systems (e.g., some BBS sites).
- Note that **global variables should also be avoided** for the same reason.

Static variables

- Consider local and global variables again.
 - A local variable will be **recycled** (its memory space will be released) immediately when it is “dead.”
 - A global variable will not be recycled until the end of a program.
- A **static** variable, declared inside a block, also **will not be recycled** until the program terminates.
 - Once a static variable is declared, the declaration statement will not be executed anymore even if it is encountered again.
 - A static global variable cannot be declared as external in other programs.

Static variables

```
int test();
int main()
{
    for(int a = 0; a < 10; a++)
        cout << test() << " ";
    return 0; // 1, 1, ..., 1
}
int test()
{
    int a = 0;
    a++;
    return a;
}
```

```
int test();
int main()
{
    for(int a = 0; a < 10; a++)
        cout << test() << " ";
    return 0; // ?
}
int test()
{
    static int a = 0;
    a++;
    return a;
}
```

- One typical reason: To count the number of times that a function is invoked.
 - Why not using a global variable for that?

Good programming style

- You have to distinguish between local and global variables.
 - The location of declarations matters.
- Always try to use local variables to replace global variables.
 - Let functions **communicate** by passing values with each other. Do not let them communicate by reading from and writing into the same variables.
 - One particular reason to use global variables is to define **constants** that are used by many functions.
- You may not need static and external variables now or even in the future.
- But you need to know these things exist.

Variable initialization

- We have learned that (local) variables are not initialized automatically.
 - It is troublesome for a programmer to initialize (local) variables.
 - Why is the system so lazy?
- In fact, the system **initializes global and static variables to 0**. Why?
- Initialization takes time.
 - There are **too many local variables**.
 - There are typically few global and static variables. Efficiency matters.

```
int aaa[1000];
int test();
int main()
{
    for(int i = 0; i < 1000; i++)
        cout << aaa[i] << " ";
    for(int a = 0; a < 10; a++)
        cout << test() << " ";
    return 0;
}
int test()
{
    static int a;
    a++;
    return a;
}
```

Outline

- Basics of functions
- More about return values
- Scope of variables revisited
- **Advances of functions**

Call-by-value mechanism (1/3)

- Consider the example program.
- Is the result strange?

```
void swap(int x, int y);
int main()
{
    int a = 10, b = 20;
    cout << a << " " << b << "\n";
    swap(a, b);
    cout << a << " " << b << "\n";
}
void swap(int x, int y)
{
    int temp = x;
    x = y;
    y = temp;
}
```

Call-by-value mechanism (2/3)

- The default way of invoking a function is the “**call-by-value**” (pass-by-value) mechanism.
- When the function `swap()` is invoked:
 - First two **new** variables **x** and **y** are created.
 - The values of **a** and **b** are **copied** into **x** and **y**.
 - The values of **x** and **y** are swapped.
 - The function ends, **x** and **y** are **destroyed**, and memory spaces are released.

```
void swap (int x, int y) {
    int temp = x;
    x = y;
    y = temp;
}
int main() {
    int a = 10, b = 20;
    swap(a, b);
}
```

Address	Identifier	Value
-	a	10
-	b	20

Memory

Call-by-value mechanism (3/3)

- The call-by-value mechanism is adopted so that:
 - Functions can be written as **independent entities**.
 - Modifying parameter values do **not** affect any other functions.
- **Work division** becomes easier and program **modularity** can also be enhanced.
 - Otherwise one cannot predict how her program will run without knowing how her teammates implement some functions.
- In some situations, however, we do need a callee to modify the values of some variables defined in the caller.
 - We may “**call by reference**” (to be introduced later in this semester).
 - Or we may pass an **array** to a function.

Passing an array as an argument (1/4)

- An array can also be passed into a function.
 - Declaration: need a `[]`.
 - Invocation: use the array name.
 - Definition: need a `[]` and a name for that array in the function.
- We do not need to indicate the size of the array.
 - An array variable stores an **address**.
 - “Passing an array” is actually telling the function **where** to access the array.

```
void printArray(int [], int);
int main()
{
    int num[5] = {1, 2, 3, 4, 5};
    printArray(num, 5);
    return 0;
}
void printArray(int a[], int len)
{
    for (int i = 0; i < len; i++)
        cout << a[i] << " ";
    cout << "\n";
}
```

Passing an array as an argument (2/4)

- When an array is modified in a callee, the caller also sees it modified!
- Why?
 - Passing an array is **passing an address**.
 - The callee modifies whatever contained in those addresses.
- Let's visualize the memory events.

```
void shiftArray(int [], int);
int main()
{
    int num[5] = {1, 2, 3, 4, 5};
    shiftArray(num, 5);
    for(int i = 0; i < 5; i++)
        cout << num[i] << " ";
    return 0;
}
void shiftArray(int a[], int len)
{
    int temp = a[0];
    for(int i = 0; i < len - 1; i++)
        a[i] = a[i + 1];
    a[len - 1] = temp;
}
```

Passing an array as an argument (3/4)

- It is fine if we indicate the array size.
 - But no new memory space will be allocated accordingly.
 - That number will just be ignored.
 - They can even be inconsistent.

```
void printArray(int [5], int);
int main()
{
    int num[5] = {1, 2, 3, 4, 5};
    printArray(num, 5);
    return 0;
}
void printArray(int a[3], int len)
{
    for (int i = 0; i < len; i++)
        cout << a[i] << " ";
    cout << "\n";
}
```

Passing an array as an argument (4/4)

- We may also pass multi-dimensional arrays.
 - The k th-dimensional array size must be specified for all $k \geq 2$!
 - Just like when we declare a multi-dimensional array.
- Now they must be **consistent**.

```
void printArray(int [][][2], int);
int main()
{
    int num[5][2] = {1, 2, 3, 4, 5}; // five 0s
    printArray(num, 5);
    return 0;
}
void printArray(int a[][2], int len)
{
    for(int i = 0; i < len; i++)
    {
        for(int j = 0; j < 2; j++)
            cout << a[i][j] << " ";
        cout << "\n";
    }
}
```

Constant parameters (1/3)

- In many cases, we do not want a parameter to be modified inside a function.
- For example, consider the factorial function:

```
int factorial(int n)
{
    int ans = 1;
    for(int a = 1; a <= n; a++)
        ans *= a;
    return ans;
}
```

- There is no reason for the parameter **n** to be modified.
 - You know this, but how to prevent other programmer from doing so?

Constant parameters (2/3)

- We may declare a parameter as a **constant parameter**:

```
int factorial(const int n)
{
    int ans = 1;
    for(int a = 1; a <= n; a++)
        ans *= a;
    return ans;
}
```

```
int main()
{
    int n = 0;
    cin >> n;
    cout << factorial(n); // as usual
    return 0;
}
```

- Once we do so, if we assign any value to **n**, there will be a compilation error.
- The argument passed into a constant parameter can be a non-constant variable.
 - Only the value matters.

Constant parameters (3/3)

- Sometimes an argument's value in a caller may be modified in a callee.
 - E.g., arrays.
- If these arguments **should not be modified** in a callee, it is good to **protect them**.

```
void printArray(const int [5], int);
int main()
{
    int num[5] = {1, 2, 3, 4, 5};
    printArray(num, 5);
    return 0;
}
void printArray(const int a[5], int len)
{
    for(int i = 0; i < len; i++)
        cout << a[i] << " ";
    cout << "\n";
}
```

Function overloading (1/4)

- There is a function calculating x^y :
 - `int pow(int base, int exp);`
- Suppose we want to calculate x^y where y may be fractional:
 - `double powExpDouble(int base, double exp);`
- What if we want more?
 - `double powBaseDouble(double base, int exp);`
 - `double powBothDouble(double base, double exp);`
- We may need a lot of `powXXX()` functions, each for a different parameter set.

Function overloading (2/4)

- To make programming easier, C++ provides **function overloading**.
- We can define many functions having **the same name** if their parameters are not the same.
- So we do not need to memorize a lot of function names.
 - `int pow(int, int);`
 - `double pow(int, double);`
 - `double pow(double, int);`
 - `double pow(double, double);`
- Almost all functions in the C++ standard library are overloaded, so we can use them conveniently.

Function overloading (3/4)

- Different functions must have different **function signatures**.
 - This allows the computer to know which function to call.
- A function signature includes
 - Function name.
 - Function parameters (**number** of parameters and their **types**).
- A function signature does not include return type! Why?
- When we define two functions with the same name, we say that they are **overloaded** functions. They **must** have different parameters:
 - Numbers of parameters are different.
 - Or at least one pair of corresponding parameters have different types.

Function overloading (4/4)

- Here are two functions:
 - `void print(char c, int num);`
 - `void print(char c);`
 - `print()` can print `c` for `num` times. If no `num` is assigned, print a single `c`.

```
void print(char c, int num)
{
    for(int i = 0; i < num; i++)
        cout << c;
}
```

```
void print(char c)
{
    cout << c;
}
```

Default arguments (1/2)

- In the previous example, it is identical to give **num** a **default value 1**.
- In general, we may assign default values for some parameters in a function.
- As an example, consider the following function that calculates a circle area:

```
double circleArea(double, double = 3.14);  
// ...  
double circleArea(double radius, double pi)  
{  
    return radius * radius * pi;  
}
```

- When we call it, we may use **circleArea(5.5, 3.1416)**, which will assign 3.1416 to **pi**, or **circleArea(5.5)**, which uses 3.14 as **pi**.

Default arguments (2/2)

- Default arguments must be assigned **before** the function is called.
 - In a function declaration or a function definition.
- Default arguments must be assigned **just once**.
- You can have as many parameters using default values as you want.
- However, parameters with default values must be put **behind** (to the **right** of) those without a default value.
 - Once we use the default value of one argument, we need to use the default values for **all** the **following** arguments.
- How to choose between function overloading and default arguments?

Inline functions (1/2)

- When we call a function, the **system** needs to do a lot of works.
 - Allocating memory spaces for parameters.
 - Copying and passing values as arguments.
 - Record where we are in the caller.
 - Pass the program execution to the callee.
 - After the function ends, destroy all the local variables and get back to the calling function.
- When there are a lot of function invocations, the program will take a lot of time doing the above switching tasks. It then becomes **slow**.
- How to save some time?

Inline functions (2/2)

- In C++ (and some other modern languages), we may define **inline functions**.
- To do so, simply put the keyword **inline** in front of the function name in a function prototype or header.
- When the compiler finds an inline function, it will **replace** the invocation by the function statements.
 - The function thus does not exist!
 - Statements will be put in the caller and executed directly.
- While this saves some time, it also expands the program size.
- In most cases, programmers do not use inline functions.